

Owner's Manual

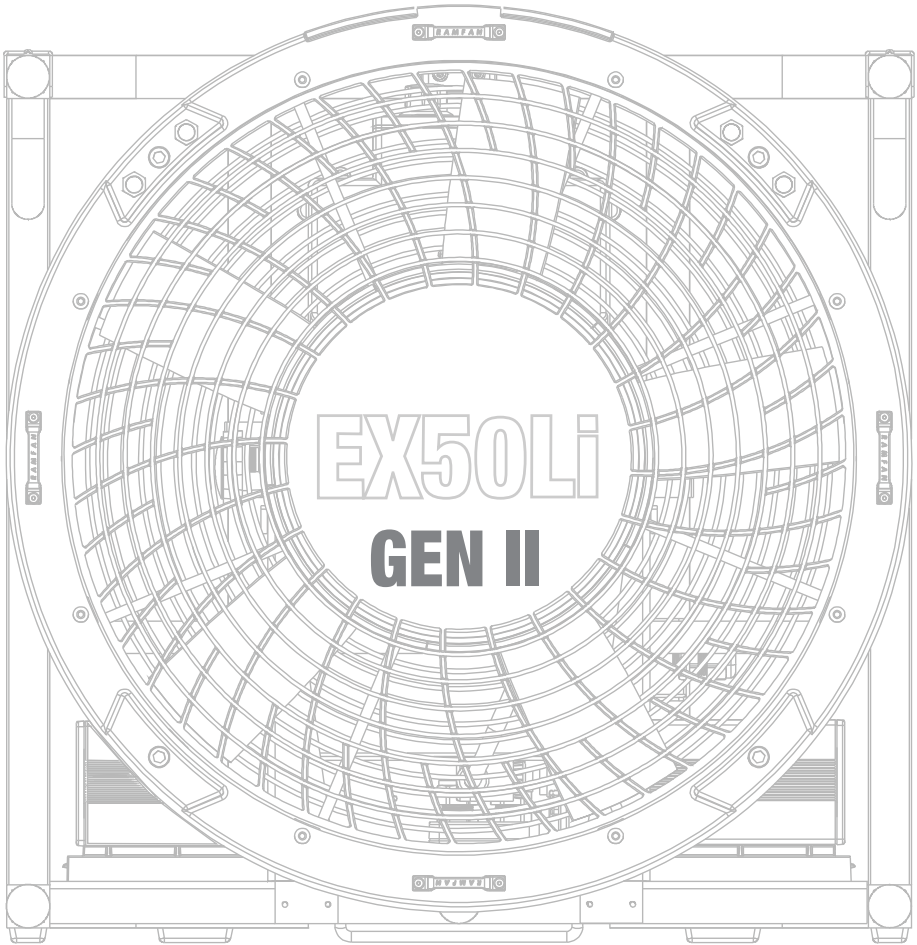

ALL PURPOSE-BATTERY VENTILATOR

! READ MANUAL BEFORE STARTING FOR THE FIRST TIME!

Thank you for purchasing the RAMFAN® EX50Li battery powered multi-purpose ventilator manufactured in the USA by Euramco Group, Inc.

For more than 50 years Euramco Group has been on the cutting edge of industrial, fire, and marine ventilation products. Each of our blower/exhausters, PPV & LSV fans and accessories represent the finest technologies available. Every product is constructed to demanding and exact specifications for quality, performance, and reliability.

When human life depends on having a fan that can deliver clean, safe air, you have only one choice you can trust: RAMFAN.

Explore our website and online catalog at www.ramfan.com and discover how RAMFAN can make a difference in the field!

All product information in the publication is based on the most current information available at the time of printing. Euramco Group, Inc. reserves the right to make changes at anytime without notice.

RAMFAN products are warranted against manufacture defect. Failure to properly maintain product will invalidate warranty coverage. Please visit www.euramco.com for warranty details.

PRIOR TO FIRST USE

1. Operate on AC voltage, 85-264V, 50/60 Hz 1Φ, for charging and discharging.
2. The unit is suitable for use on Ground Fault protected circuits.
3. Should the provided AC connector be unsuitable, replace with desired connector containing a grounding circuit. Check continuity from ground terminal to motor shell.
4. Place batteries into holders and connect to IP66 connectors, Fully charge prior to first use.
5. This fan is for emergency service use. Charge fully between runs. Create a charging protocol.
6. To charge, turn the speed control fully to the left (OFF) and then connect to AC outlet. Indicator lights will illuminate, and then go off. When charging commences, indicator lights will show state of charge. Charging should complete in 3-4 hours, with the indicator lights turning green.
7. For DC operation with AC disconnected, hold the wake button until indicator lights come on showing battery state. Advance speed control.
8. For AC operation, advance speed control.



CONTENTS

- Unit Description** 4
- Warning Labels & Safety Pecautions** 5
 - Specifications 5
- Main Interface** 6
- Adjusting Angle** 7
- Operational Modes** 8
 - AC Operation 8
 - DC Operation 8
- Connection of Battery Pack** 8-9
- Battery Operation Procedures** 10
 - Run Time 11
 - Charging Procedure 12
- Battery Status Indicator Lights** 13
 - Battery Pack Protection 13
 - Storage/Transport Modes 14
 - How to Activate "Storage/Transport Mode" 14
 - AC Power Cord 15
 - Operating Limitations 15
- Lithium-Ion Battery Maintenance Guidelines**16
 - Overview 16
 - Storage 16
 - Recommendation16
- Maintenance and Disposal** 17
 - Maintenance Schedule 18
 - Accessories 19
- Certification** 20
- Declaration of Conformity**..... 21
- Parts Exploded View & Index** 22-24
- Plug Types** 25

Unit Description

The EX50Li is a multi-purpose ventilator powered by battery(s) or single phase AC. The flexible frame configuration allows for PPV, Smoke Ejector or ducted blower use in both normal, horizontal and hanging positions.

The motor is a variable-speed BLDC motor controlled by a microprocessor integrated with a power supply, dual battery charger and an LED light driver.

The EX50Li will run with one or two 40V (6Ah) Li-ion battery packs. Each pack yields up to 23 min of operation at full power. Extended operation is achieved by reducing speed. The batteries may be swapped during operation.

AC voltage can be applied while running on batteries and the ventilator will auto-switch to AC power. Conversely, the AC power can be removed and the unit will auto-switch to battery power, if sufficient charge remains.

The integrated battery charger will charge one or two fully discharged battery packs in 4 hours or less.

LED scene lights are integrated into the ventilator shroud and 3-intensity infinite switch knobs: high, low, & off. Hold to change. The LED knob selects the scene lights output level in a row. Clockwise Progression: Off ▶ Full ▶ Half ▶ Off.

The integrated controller is EMI-protected to prevent interference with radio communication.

A simple Control Panel on the top of controller controls all functions.

Warning Labels & Safety Precautions

- Electrical shock hazard. Do not open enclosures.
- **DO NOT START** with signs of visible damage.
- Blower is not intended for operation in explosive atmospheres.
- Wear ear protection when close by.
- Keep body parts and loose objects away from intake of fan.
- Do not move while running.
- Operate and repair by trained personnel only.
- Always use grounded plug and properly ground AC power receptacle.
- Heat sink becomes hot during operation and charging. LED lights become hot during use. Do not touch.
- Use with approved, good condition extension cord with ground connector.



Wire Gauge Requirements per ft (m)	
0-150 ft (0-50m)	AWG 14 (2.5 mm ²)
>150 ft (> 50m)	AWG 12 (4 mm ²)

Specifications

Model	EX50Li 18"/46 cm	
Order#	EL5500 / EL5500-230	
Motor	1.20 Hp / 0.89 kW, BLDC	
Runtime @ Max. Speed	DC: 90 minutes (four battery packs) DC: 45 minutes (two battery packs) AC: Unlimited	
Power AC	Universal Input: 85-264V 1Φ, 50/60 HZ	
Battery System	40V Lithium-ion, 432Wh, 14Ah	
IP Rating (Motor/Battery System/Controller)	IP66 / IP66 / IP66	
Dimensions (h x w x d)	22" x 21" x 12" in / 56 x 53 x 30 mm	
Weight	with two batteries: 54 lbs / 25 kg with one battery: 50 lbs / 23 kg without batteries: 45 lbs / 20 kg	
Operating Temp Range	-4°F to 105°F	-20°C to 40°C
Charge Temp Range	-32°F to 105°F	-0°C to 40°C
Tilt	-10° to + 34°	
Approvals	CE AMCA	
AMCA Verified Airflow		
AC Power Supply	9,635 cfm (16,370 m ³ /hr)	
DC Power Supply	10,120 cfm (17,194 m ³ /hr)	



Main Interface

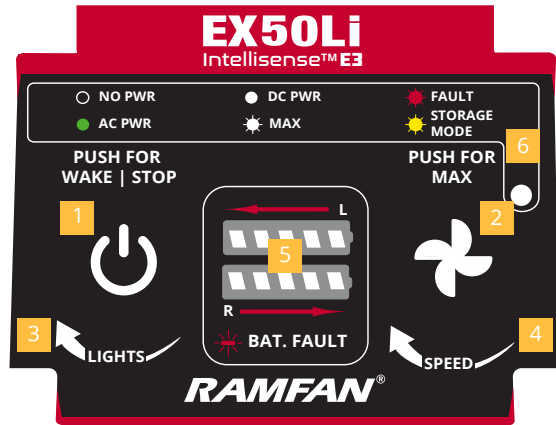

Number	Symbol	Indicate Function
1		Wake Button / Emergency Stop Button Press and hold WAKE button to start.
2		Maximum Speed (DC) Button Press MAX button for 2 seconds.
3		LED Scene Lights knob On, off, on high or on low.
4		Speed Control knob Controlled operation from 0 to full speed
5		Battery status LED lights strobe during charge; remains on for 5 min when charging is complete.
R		Ventilator Status LED Lights See table below for details.

Color	Status	Description
Off	NO PWR	Power is off
Green (Solid)	AC PWR	Ventilator is connected on AC Power Supply
White (Solid)	DC PWR	Ventilator is running on DC Power Supply
White (Flashing)	MAX	Ventilator is running on Maximum speed - DC Power Supply
Red (Flashing)	FAULT	Fault on the ventilator
Yellow (Flashing)	STORAGE MODE	Storage/Transport Mode

Adjusting Angle

Perform this procedure to adjust the position of the ventilator. Use your hand to unscrew the tilt adjustment knob, and then lock it in place from above, and held in the inclined position by tightening the knob. For negative tilt, use the negative tilt bracket. This provides tilt up/down adjustment, from -10 to +34 degrees.

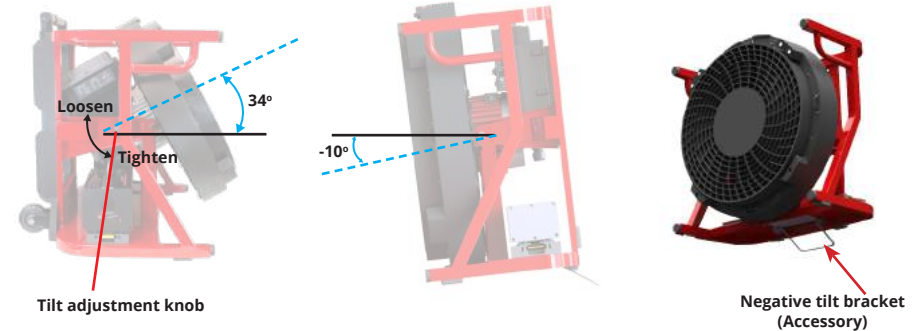

For confined space rescue operations, you can place the ventilator directly on top of a manhole. Tilt range from -90 to +90 degrees. Note that those positions can direct airflow downward or upward



Operational Modes

AC Operation

- Input Voltage. 90-250VAC, 50/60Hz
- The ventilator is capable of operating seamlessly in countries that supply electricity at either 120V AC/60 Hz or 240V AC/50 Hz without manual adjustments by the user.
- Operation out of these limits can damage electrical components and will void the warranty.

1. Connect the fan to an AC power source.
2. Status LED Light will automatically turn green, displaying the status "Ventilator is connected on AC Power Supply".
3. Start the ventilator by using the Speed Control knob to the desired speed.
Note: You can keep the batteries on their location without charging the battery. Battery Indicator Lights will turn off because there is no battery charging when ventilator is running on AC.
4. When the fan is powered off, Status LED Light will automatically turn off after 1 hour and the battery Indicator Lights will redisplay battery charge level of each battery pack detected. The ventilator will begin charging the battery packs after 60 minutes of idle time.

DC Operation

Connection of Battery Pack

- Plug the ventilator connector cable (red) into the battery connector.
- Set the installation index on the battery with the cable, lining up with the cable connector.
- Press the connector lock and rotate the red piece clockwise (a quarter turn to the right) in the most careful way possible.
- Align the edge of the battery pack with holder under the red line where it says, "Align battery EX50Li" and firmly slide the battery in the direction of the arrow as shown in the illustration until a loud click is heard.

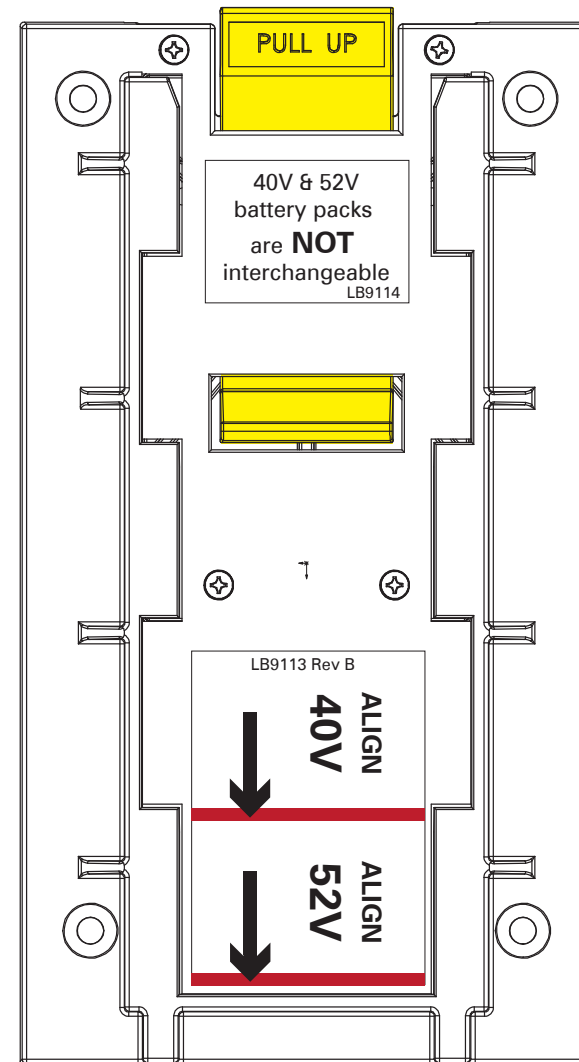

- Gently pull up the yellow handle to remove the battery from the holder.



Battery Operation Procedures

Please full charge battery before first use

Using one or two Batteries

- The EX50Li allows the option of using one or two battery packs.
- When using one battery, simply plug the battery into either one of the two battery connectors (left, right or both).
- Be sure to secure the unused battery connector by placing electrical tape over the contacts.
- When powered on, the system will identify quantity of batteries and locations used.
- For a true redundant system, two batteries are recommended.
- When using dual batteries, it's important that both batteries be of the same charge level and ideally of the same age and condition.
- The control system will control all battery charge and discharge during use.
- Battery status will be displayed on control panel.

Battery Operation Procedures

- When AC is disconnected and Speed Control is off (speed = 0), the controller and battery(s) will enter a sleep mode to conserve the battery power after 60 minutes of no activity.
- To wake the ventilator, push and hold WAKE | STOP Button  on Control Panel. Battery Status LED Light will show white solid for the status. The unit will return to sleep mode if not used within 10 minutes.
- The ventilator starts at the lower speed = 0. Speed will vary by 11 levels - from 11 (highest) to 0 (off). Turn clockwise to increase speed. At level 11 (the highest), if keep turning the control knob clockwise, the speed will not change, it will stay at highest speed all the time. To slow down, turn counterclockwise.
- If you want to increase the speed, push and hold the MAX Button  Ventilator Status LED Light will flash white for the status. Remember that this will only work when 2 batteries are connected to the ventilator and when it is operating exclusively on DC current source (battery).
- To STOP the ventilator, push and hold WAKE | STOP Button  on Control Panel. Battery Status LED Light will be unlit.
- Battery(s) may be swapped for charged batteries at any time.
- Reduce run speed to minimum required to increase runtime.

Run Time

Run time refers to how long the ventilator on battery power will last under a given load. We will assume both batteries have full charge beforehand and also 100% efficiency (Read "Factors that affect Battery Life" section):

	2 Batteries	Speed Level Knob
At maximum speed	45 minutes	11
At maximum speed and Max button activated	30 minutes	Max button activated 

Charging Procedure

Make sure the battery pack is connected correctly to the ventilator, as described above in “**Connection of Battery Pack**”.

- The next step is to leave the ventilator off. During charging, the battery indicator lights will flash. The battery charge level can be recognized by the number of lights that are constantly lit.
- When batteries and AC are connected, the batteries will begin charging after 60 minutes of idle time.
- Indicator lights will show charge state during charging. Charging should complete in about 5 hours, with the Battery Status Indicator lights turning green. Should the Speed Control be turned counterclockwise on during the charge, charging will stop, and the ventilator will start. Charging will begin again after 60 minutes of idle time.
- After charging is complete, the chargers will maintain the battery(s) by keeping the ventilator connected to AC.
- While charging, the battery status LED lights will strobe. The batteries will be disconnected at the end of their charge automatically. At the end of charging, the current power is displayed for 5 minutes and then the lights will be turned off.

Battery Status Indicator Lights

On the control panel there are 2 sets of lights: on the top side of the battery lights indicate the charge level in the battery attached to the left side of the ventilator, on the bottom side of the battery lights indicate the charge level in the battery attached to the right side of the ventilator.

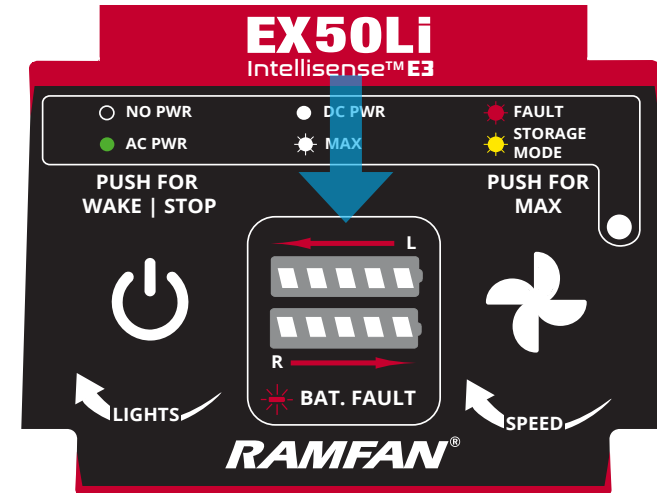

If the battery is charging, the green indicator lights will horizontally scroll from left-to-right, turning solid green when the battery is fully charged.

If the ventilator is running on battery power, the estimated remaining battery time is shown.

If all the lights flash red, this indicates that the battery has failed and the battery must be replaced.

Battery Pack Protection

- To protect itself from damage and extend its life, the battery pack's intelligent circuit monitors current draw and temperature. In extreme situations, the battery pack will turn OFF the ventilator if the current draw becomes too high.
- While a battery undergoes a charge cycle, its temperature rises. To prevent grid corrosion and eventual battery failure, allow the battery to cool down in between charging and discharging.

Storage/Transport Modes

Lithium-ion cell manufacturers recommend that battery cells be stored at 30% state of charge (SoC) for best long-term health and stability. Further, IATA (International Air Transport Association) Dangerous Goods Regulations (DGR) state that all lithium-ion batteries must not exceed 30% SoC at time of shipment.

RAMFAN battery-powered fans built with Intellisense™ E3 controllers are equipped with integrated "Storage/Transport Mode" to make it easy to comply with storage recommendations and transport regulations by automatically discharging installed battery pack(s) to 30% SoC.

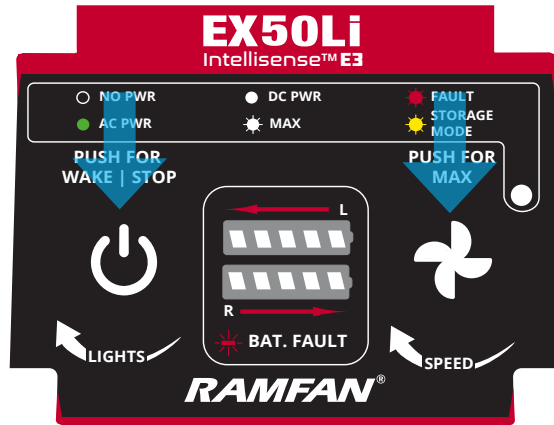

How to activate "Storage/Transport Mode"

1. AC power must be disconnected for Storage/Transport Mode to be activated.
2. Press and hold both the WAKE | STOP and the MAX buttons, together for 8 seconds, until the status LED light changes to yellow flashing.
3. Once activated, fan will automatically turn at low RPM until battery pack reaches 30% SoC. Once 30% SoC reached, fan will turn off.

Storage/Transport Mode can be interrupted by turning Speed Control at any time during the operation.

Storage/Transport Mode can be engaged with either one (1) or two (2) battery packs installed on the fan.

AC Power Cord

This battery fan was designed to replace corded AC fans, optimizing cordless operations. The AC power cord is designed to be removable for the convenience of those users who choose to operate cordless.

The AC power connector is a "Push-Pull" locking system where the outer (blue) slide must be pulled back, in line with the cable, to securely engage connector.

- When AC power is needed, push (blue) connector onto (black) inlet on fan controller. Check that it is securely engaged.
- When disconnecting the AC power cord from fan, pull back on (blue) slide to disengage and gently remove. Store in marked frame position when not in use.

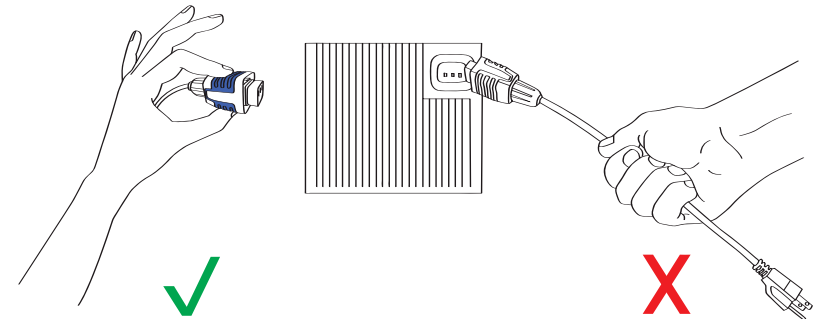

Pull the plug out itself, never by the cord or by wiggling it out of the outlet.

Operating Limitations

RAMFAN lithium-ion battery packs are designed to operate in a wide range of temperatures. Due to the chemistry of lithium ion battery cells, different operational limits apply to discharge and charge functionality.

- Temperature range (discharge): -20°C to +45°C (-4°F to +113°F)
- Temperature range (charge): 0°C to +40°C (32°F to 104°F)

A "cold soaked" battery may not power a fan or be able to take a charge. If this occurs, warm up cold battery at room temperature 20°C (68°F) and try again.

Lithium-Ion Battery Maintenance Guidelines

Battery packs do require routine maintenance and care to maximize their useful life and maintain warranty coverage. Read and follow the guidelines in this manual to safely use your lithium-ion battery packs and achieve battery life span.

Overview

According to leading cell manufacturers (LG, Samsung, Panasonic), the estimated life of a lithium-ion battery is 500 charge cycles. When stating approximate useful life of a battery in units of “charge cycles,” cell manufacturers define this as the point where the battery capacity (Ah) is reduced to 80% of original. This means battery is not “dead” after 500 charge cycles, but runtime is significantly reduced, and replacement should be considered.

Partial discharge of lithium-ion batteries is fine. There is no “memory effect” and the battery does not need periodic full discharge cycles to prolong life.

Storage

When storing, remove battery packs from fan and store in a dry and cool location. Avoid extreme temperatures.

- Recommended Storage Temperature: 5°C to 20°C (41°F to 68°F)
- Maximum relative humidity during storage: 90% RH

NOTE: all batteries self-discharge during storage. Higher temperature (>20°C or 68°F) reduce the battery storage life.

Lithium-ion batteries should be stored in a charged state, ideally around 30% state of charge (SoC). See “Storage/Transport Mode” section of this manual for easy discharging steps to follow before storing battery packs.

Long-term (>6 months) storage of battery packs is not recommended. When a battery pack has been unused for 6 months, check the charge status and either charge or dispose of the battery as appropriate.

Recommendations

- Battery packs will last significantly longer when run in pairs (two battery packs per fan) as there is 50% less discharge current per pack.
- As with any equipment, batteries will wear out faster with heavy use. Depth of Discharge (DoD) determines the cycle count of the battery. The smaller the discharge (low DoD), the less stress is enacted on the chemistry of the battery and the longer the battery will ultimately last. Ideally, operators should avoid full discharges and charge the battery after every use.

Maintenance and Disposal

- DO NOT disassemble the ventilator for maintenance reasons.
- Do not loosen screws on control box without contacting Euramco customer service. They are torqued to a setting to achieve water tightness.
- Completely unravel power cord and place unit on a flat, stable surface. Clean ventilator periodically to remove accumulated dust or particles from ventilator guards, impeller blade and heat sink in rear of controller (ribbed). Use only biodegradable detergents. If power washing, avoid controller housing especially gaskets and control panel.
- Contact factory for replacement parts and installation instructions. To order spare parts call Euramco Group **+1.619.670.9590** or **theteam@euramco.com**
- Always dispose of your battery pack according to federal, state and local regulations.
- Even discharged batteries contain some energy. Before disposing of, use electrical tape to cover the terminals to prevent the battery pack from short circuit.
- Properly dispose of battery packs when necessary. Contact your local hazardous materials e-waste collection department for details or proper disposal of rechargeable batteries.

Maintenance Schedule

Battery packs should be inspected regularly for mechanical damage.

- Dropping, or any other heavy impact, may compromise water ingress protection. Quickly inspect for obvious damage after every use. If damage is noted, contact Authorized Service Center for inspection, testing, and maintenance.
- Damage to gasket may compromise water ingress protection, increasing risk of pack failure.
- Do not store in same compartment with combustible or highly flammable material as gasoline and diesel oil.
- Liquid damage is not covered under warranty.

REGULAR SERVICE PERIOD		After Each use	Every 3 months	Every 6 months	Every year
Perform at every indicated month or operating hour interval, whichever comes first.					
ITEM					
Fan Inlet/Outlet Gaurds	Visual Check	•			
	Clean			• ⁽¹⁾	
Impeller	Visual Check	•			
	Clean				• ⁽¹⁾
Control Box Gaskets	Visual Check	•	• ⁽²⁾		
	Replace if necessary				• ⁽³⁾
Electrical Cables	Check	•			•
Rubber Feet	Check				•
Battery Packs:					
Gaskets	Visual Check	•	• ⁽²⁾		
	Replace if necessary				• ⁽³⁾
Electrical Connector/USB Connector	Visual Check	•	• ⁽²⁾		
Internal Diagnostics	Plug into USB if equipped				• ⁽³⁾

(1) Clean more frequently when used in high-sediment areas.

(2) Check immediately if dropped, or damage may affect water ingress protection.

(3) These items should be serviced by your RAMFAN servicing dealer, unless you have the proper tools and are mechanically proficient. Refer to RAMFAN service manual for service procedures.

Failure to follow this maintenance schedule could result in non-warrantable failures.

Accessories

1. External Battery Charger

Charge batteries on fire apparatus
Order # R25515DC
Charge batteries at fire station
Order # R25515

2. Swappable 40V Li-Ion Battery Pack

Spare Battery (recommend ordering 2)
Order # R2-360-AH-U

3. Vehicle Mount Kit

Custom mount that perfectly fits fan
Order # EL610K

4. Integrated Rehabilitation Mister

Order # EL8111

5. HI-Expansion Foam Adapter

Foam adapter converts EX50Li into a high expansion foam generator
Order # HI-500

6. Convert to a Smoke Ejector

Door Bar and Hangar Kit
Order # EL7095K
Hanger Kit (if you already own door bar)
Order # EL8095

7. Convert to Confined Space Rescue Fan

18"/46cm duct (16.4'/5m length)
Order # FDT-185MSR
18"/46cm duct (32.8' / 10m length)
Order # FDT-181MSR

8. Shoulder Strap

Order # EL6013

9. Rubber Feet

Rubber foot (Set of 4) + Screws for EX50Li frames

10. Mister Adapters

Double Female NH 1" Adapters
Order# WF20-0252
1" BSP TO STORZ
Order# GX-8020



FlowPath™ Control

AMCA Certified RAMFAN PPV TurboVentilator

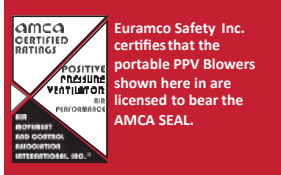

Euramco Safety Inc. certifies that the portable PPV Blowers shown here in are licensed to bear the AMCA SEAL.

Euramco Safety Inc. certifies that the Portable PPV Blower shown below is licensed to bear the AMCA Seal. The ratings shown are based on tests and procedures in accordance with AMCA Publication 211 and comply with the AMCA Certified Ratings Program.

Why We Use AMCA

AMCA, The Air Movement and Control Association International, has been in existence for nearly 80 years and is the world's only recognized authority for the development of standards and measurement of air movement.

Our commitment to AMCA Certification is your verifiable assurance that every RAMFAN PPV Turbo Blower will perform exactly as specified.

SPECIFICATIONS AND PERFORMANCE RATINGS

MODEL	SIZE		HP	DIMENSION (HxWxD)		MOTOR MFG/MODEL N ^o	WEIGHT		RPM	SETBACK		ANGLE		AIRFLOW @ FULL SPEED		POWER SUPPLY
	in	cm		in	cm		lbs	kg		ft	m	tilt	cfm	m ³ /hr		
EX50Li	18	46	0.8	22x21x12	56x53x30	EL5500 / EL5500-230	45	20	2798	14	4.3	13°	9,635	16,370	AC	
EX50Li	18	46	0.8	22x21x12	56x53x30	EL5500 / EL5500-230	45	20	3045	14	4.3	9°	10,120	17,194	DC	

Performance ratings do not include the effects of appurtenances (accessories).

RAMFAN's fire fighting PPV Series outperforms larger blowers in their class with their precision balanced TurboForce Impellers that maximize airflow. These PPV blowers have proven to be effective in controlling airborne contaminants, replacing interior air, removing heat and supplementing fixed ventilation systems. By pressurizing properly and controlling the resultant flow path, these changes occur very rapidly. This is accomplished by using these specialized blowers with the power and velocity to pressurize the interior of a structure or building.

September 2021



Euramco Group

2746 Via Orange Way | Spring Valley, CA 91978 USA | (800) 472-6372 | (619) 670-9590

WWW.RAMFAN.COM

PROUDLY MADE IN CALIFORNIA



Parts Exploded View

EX50Li Gen II

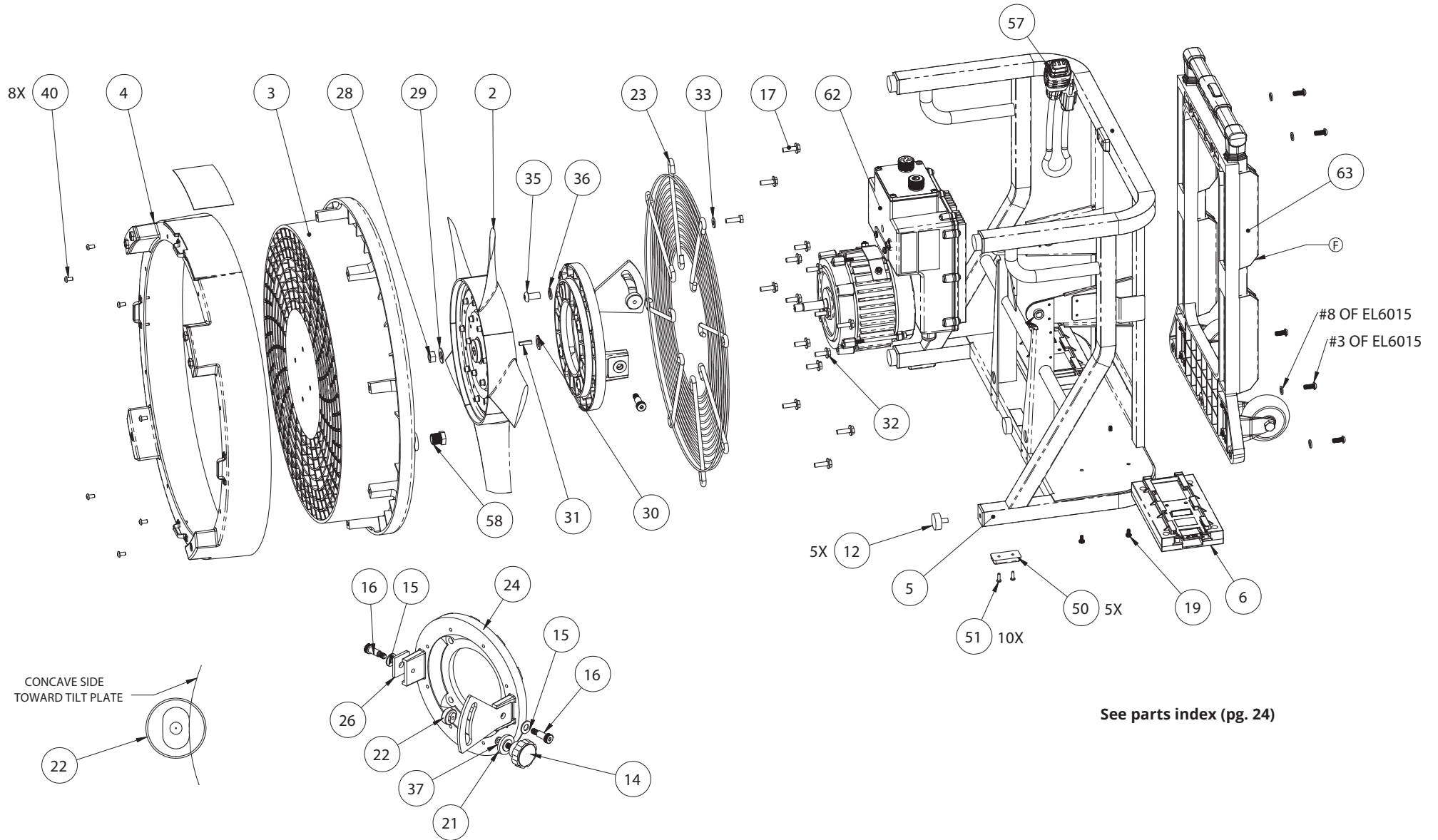

Parts Exploded View

EX50Li Gen II Index

Component Description	Bubble #	Part #
IMPELLER, 5 BLADE 17.65" 1.8HP@3800RPM	2	BL226
SHROUD, MOLDED, 18"/460mm	3	GH4015
EX50Li SHROUD COVER ASSEMBLY	4	EL2300
BATTERY MOUNT ASSEMBLY	6	R2-MOUNT360AHU
RUBBER FOOT, 50 DURO	12	FZ-MM9873
KNOB, 1/4-20 INSERT	14	FZ-KNOOB-4210
3/8"X3/4" OD NYLON WASHER	15	FF99454
SHOULDER BOLT, 3/8 X .75, S/H	16	FZ-BOLT-A622
Capscrew, 1/4-20 X 7/8",H/H, Pltd Stl	17	FA9506520
SCREW, 8-32 x 3/8" PH,SEMS,EXT	19	FA95062444
WASHER, TILT SPACER, EX50Li	21	EL0151-101
CLAMP, TILT GUIDE	22	EL0151-100
GUARD,INLET, 18"FLAT	23	EL4001
MOTOR MOUNT TILT PLATE, MACHINED/WELDED	24	EL3202
SPACER BLOCK, TILT PLATE	26	EL-320004
HEX NUT, 7/16-20, NYLOCK, THIN	28	FE96106NY
7/16" FLATWASHER, SAE, PLTD	29	FF96684SAE
1/2" FLATWASHER, SS AN960	30	FF91467AN960
KEY, 3/16" x .75"L IMP.	31	EA7020
1/4" FLATWASHER, SAE, PLTD. STL.	33	FF96439SAE
3/8-16X3/4" B/H C/S STL	35	FZ9509482-BH
3/8 L/W STEEL	36	FG95450
.250 NYLON WASHER .062	37	FF99432
#6 x 1/2" P-TRUSS, SMS, PLTD STL.	51	FZ9500461-PT
POWER CORD,QUICK DISCONNCT,Type E/F Schuko	57	EL-CUS-4762
PIPE PLUG, 3/8" NPT MACHINED	58	FH93816-MACH
MOTOR/CONTROLLER ASSY G2	62	EMC-E55010G2
Telescoping Handle Wheel Kit, EX50Li, Factory Install	63	EL6015

Plug Types

The EX50Li is suitable for worldwide applications. Both a voltage & frequency converter is not needed. The unit includes a simple removable cord that allows the unit to operate up to 250 VAC, 50 Hz and 60 Hz:

Mainly used in	Type	Order #
North and Central America, Japan	B	EL-CUS-4762
France, Belgium, Germany, Austria, the Netherlands (and most European countries)	E/F	EL-CEU-4762
United Kingdom, Ireland, Malta, Malaysia and Singapore	G	EL-83070-4762
Australia, New Zealand, Papua New Guinea and Argentina	I	EL-84040-4762
China	I	EL-84640-4762

If it becomes necessary to use a power cord with another plug standard, order the power cord that matches the electrical requirements of the country or area. The physical adapter for the outlet is interchangeable for use in different countries and allows you to swap the cable yourself into the socket.



SM-EXSOLI GEN II REV J1
061223

USA

2746 Via Orange Way
Spring Valley, CA 91978 USA
Toll Free: (800) 472-6326
Phone: +1 (619) 670-9590
Fax: +1 (619) 670-7345
theteam@euramco.com

EUROPE-LUXEMBOURG

68, Avenue de la liberte
1931 Luxembourg
Phone: +352-26008055
Fax: +352-26008056
theteam@euramco.com

SINGAPORE

J1 Fullerton Road
#02-01 One Fullerton
Singapore 049213
Phone: +65-9773 33 35
theteam@euramco.com

CHINA

No.239,Guian South
road, ZhenHai District,
NingBo, China, 315201
Phone: +86-574-87979390
Fax: +86-574-87979391
saleschina@euramco.com