



Euramco Safety

**GX200/
GX200L**



Owner's Manual



Euramco Safety, Inc.
2746 Via Orange Way
Spring Valley, CA 91978 USA
USA 1.800.4.RAMFAN
Tel +1.619.670.9590
Fax +1.619.670.7345
theteam@euramcosafety.com

www.EuramcoSafety.com

SM-GX200

Preface

Thank you for purchasing the RAMFAN® GX200 or GX200L Positive Pressure Ventilator manufactured by Euramco Safety, Inc.

For more than 30 years Euramco Safety has been on the cutting edge of industrial, fire, and marine ventilation products. Each and every one of our blower/exhausters, smoke ejectors, PPV & LSV fans and accessories represent the finest technologies available. Every product is constructed to demanding and exact specifications for quality, performance, and reliability.

When human life depends on having a fan that can deliver clean, safe air, you have only one choice you can trust: **RAMFAN.**

Explore our website and online catalog at www.EuramcoSafety.com and discover how RAMFAN can make a difference in the field!

This manual covers operation and maintenance procedures for the RAMFAN GX200/GX200L Positive Pressure Ventilators.

All product information in the publication is based on the most current information available at the time of printing. Euramco Safety, Inc. reserves the right to make changes at any time without notice.



READ MANUAL BEFORE STARTING FAN FOR FIRST TIME!



Table of Contents

1 Specification & Warning Labels	3
2 Features & Benefits	4
3 Safety Precautions	5
4 Preparation for Use	6
5 Operation	6
5.1 Control Features.....	6
5.2 Run Procedure	7
5.2.1 Start Up	7
5.2.2 Shut Down	7
6 Maintenance	7, 8
7 Storage	8
8 Troubleshooting	8
9 Spare Parts	9, 10

1 | Specification & Warning Labels

Specifications:

GX200/ GX200L SPECIFICATIONS			
MODEL	WEIGHT	DIMENSIONS	ENGINE
GX200L	36lbs/ 16kg	22hx18.5wx20d in 559x470x508 mm	HONDA 2.1Hp GXH50
GX200	48lbs/ 22kg	20.5hx19.5wx20.5d in 550x500x520 mm	HONDA 2.1Hp GXH50

RAMFAN is a brand name of Euramco Safety, Inc. | Ph +1.619.670.9590 | www.EuramcoSafety.com

LB6272

Cautions & Warnings:

CAUTION • PRECAUCIÓN • ATTENTION • VORSICHT • 注意!

Not for use in flammable or explosive atmospheres!
 No utilizar en entornos inflamables o explosivos!
 Ne pas utiliser dans une atmosphère inflammable ou explosive!
 Nicht in einer leicht entzündlichen oder explosionsgefährdeten Umgebung verwenden!
 릿弄침弄곡뻘씩苟賣痰！禁止在易燃易爆环境下使用!







LB6233 Rev A



2 | Features & Benefits

GX200/GX200L | 16"/40 cm

Lightweight Gas-Powered PPV with **PowerStream® Technology**

Fan output is only half the story in PPV. RAMFAN ventilators' penetrating, high velocity airflow means faster cooling and clearance of dangerous smoke and toxic gases. PowerStream® Technology straightens the airflow and literally cuts into the dangerous heat and smoke layer to quickly clear and cool the way for advancing firefighters.

The NO COMPROMISE Leader

RAMFAN® is the brand leader in quality portable ventilation as a result of Euramco Safety's "No Compromise" approach to user safety, product design and performance. RAMFAN fans are built using premium components and tested to meet high standards in performance and safety.

NO COMPROMISE Design and Performance

- PowerStream® Fans straightens the airflow for greater setback distances
- Compact, for easy storage in typical engine compartments
- Low CO Emissions
- Polymer TurboForce™ Impeller for increased shatter resistance and enhanced PPV performance
- Vibration isolating feet for stability on hard or slippery surfaces
- Welded Frame with wide footprint reduces vibration and lengthens service life. No bolts to shake loose!

GX200

- ⇒ Weighs Only 48lbs!
- ⇒ Steel "roll cage" Design
- ⇒ Cart style frame for easy maneuvering
- ⇒ ONE-Step™ tilt adjustment - Easily change the angle of the fan from 0°-18° to ventilate over steps, porches and slopes
- ⇒ Semi pneumatic tires

GX200L

- ⇒ Weighs Only 36lbs!
- ⇒ Simple. Fixed 15° tilt to quickly position fan and establish flow path
- ⇒ Aluminum Alloy Frame
- ⇒ Wrap around carry bar to easily grip and carry with one hand on the front or a hand on each side

3 | Safety Precautions



DO NOT START fan if there are any signs of shipping damage, particularly to blade, guards, or housing. If ANY damage is suspected, STOP and call your dealer immediately.



Do not stand near engine exhaust, engine exhausts poisonous carbon monoxide.



Use safe lifting practices.



Keep fingers, hair, debris, food or any loose objects away from intake of fan.



Wear eye protection.



Wear ear protection.



Gasoline in engine is flammable.



Start ONLY if fan is sitting in a stable and upright position.



DO NOT move fan while in operation.

- Operate the fan on a level surface whenever possible, NOT to exceed 20°.
- Do not spill fuel on the fan.
- Do not overfill the fuel tank.
- Avoid using fuels that are high in methanol or ethanol additives.
- Do not smoke around the fan.
- Always check for oil and gasoline leaks before starting motor.
- Do not stand directly in front of the fan.
- Turn fan OFF if you hear unusual noises.
- Exercise care during deployment and storage to prevent physical damage.
- Allow fan to cool before storing.

4 | Preparation for Use

Ventilator

1. Position the fan on a level surface.
2. Slowly pull on the recoil starter cord; listen to verify fan blades are not rubbing on shroud. Repeat. If rubbing is heard, STOP, call your dealer.
3. GX200: Adjust the fan tilt so the engine is level, there are 5 locking positions.
GX200L: Pre-tilted, DO NOT attempt to adjust tilt angle.
4. Ensure all motor controls are in the OFF position: Choke, Fuel Switch and Engine Switch.
5. Adjust Throttle to lowest position.
6. Fill the Honda Motor crankcase with oil as described in the HONDA engine manual. Use extreme caution to prevent oil from overflowing the port on top of the motor.
7. Fill fuel tank with fuel. (see Honda Engine Manual). **AVOID using fuels that are high in methanol or ethanol additives.** If used, methanol fuels must contain co-solvents and corrosion inhibitors.

5 | Operation

5.1 | Control Functions & Features

Fuel tank	Runtime 1 hr 40 min
Throttle	Turtle - Slow speed, Rabbit - Fast speed
Choke	The choke closes the carburetor air valve to provide a rich gas mixture (Pull for cold start).
Fuel Cock	To prevent flooding the carburetor float chamber, close the fuel cock during long periods of non-use, transport and storage.
Pull Starter	Pull start engine with recoil starter cord.
Honda GXH50 Engine	See Honda Engine Manual.
Tilt Mechanism	GX200: ONE-Step™ Tilt adjustment for fast, easy set-up. GX200L: Pre-tilted to 15°, fixed position.
Engine Switch	“ON” for starting engine, “OFF” for shut down.
Rubber Feet	Rubber feet and wide footprint reduces vibration, lengthens service life.

5.2 | Run Procedure

5.2.1 | Start-Up

- 1 Read the Owner's Manual completely before starting fan.
- 2 Wear both eye and ear protection.
- 3 Complete checks as indicated in Section 4, Preparation for Use.
- 4 Position the fan on a level surface at your desired setback distance.
- 5 Using the Tilt Mechanism, adjust fan to the desired angle (GX200 Only).
- 6 Turn the Choke ON if the engine is COLD START, turn the Choke OFF if the engine is WARM START.
- 7 Turn the Engine Switch ON.
- 8 Set motor Throttle to IDLE / LOW speed.
- 9 Pull the Pull Starter Cord until engine starts.

Note: If this is the first time the motor has been started it may take 15 to 20 seconds before the fuel pump can transfer enough fuel to the motor's carburetor before the motor fires-off.

- 10 Adjust the Choke to OPEN after running 4-5 seconds.
- 11 Adjust the motor Throttle to the desired airflow.

5.2.2 | Shut-Down

- 1 Turn Throttle down to IDLE
- 2 Turn the Engine Switch OFF
- 3 Turn the Fuel Cock OFF
- 4 Turn the Choke lever OFF
- 5 Pull Handle pin and fold handle forward to lay flat (GX200 Only).

6 | Maintenance

- **Follow all additional safety precautions** that your company may have for lock-out / tag-out procedures when performing any type of maintenance.
- **Do NOT disassemble blower** for maintenance reasons.

- **Clean fan periodically** to remove accumulated dust or particles using a commercially available biodegradable cleaning solution. DO NOT use solvents containing chlorinated hydrocarbons (i.e. MEK, Acetone)
- **NEVER operate fan with damaged or missing finger guards.**
- **Inspect the fan for loose fasteners** at least once every 6 months depending on frequency of use. Tighten any loose fasteners immediately. DO NOT overtighten fasteners.
- **Check rubber feet** for excessive wear or breakage.
- **Run fan for 2 hours every 3 months** to prevent the fuel from going stale.
- **Refer to the Honda Engine Manual** for maintenance schedule and instructions.
- Contact factory for replacement parts and installation instructions.

7 | Storage

- If the fan will be stored for a long period of time (3 to 6 months), add a fuel stabilizer product to the fuel tank and run engine for at least 15 minutes to replace the gasoline in the engine carburetor with the stabilized fuel.
- Store in the upright position ONLY, do not tilt or overturn fan.

8 | Troubleshooting

WARNING: Ensure blower is completely off before performing any of the below.

"FS" or Field Solutions can be handled by the technician in the field | **"AST" or Authorized RAMFAN Service Technician**

PROBLEM	CAUSE	See Above	SOLUTION
Motor turns over but won't start	Fuel tank is low or out of fuel Fuel valve not open Choke is Closed (cold start) All other issues	FS FS FS FS	Fill with fuel Open fuel valve Open choke Refer to Honda Engine Manual
Fan does not tilt up or down	GX200: Not set to desired position GX200L	FS -	Using your foot, push down on the ONES TM tilt adjustment pedal while holding the fan shroud. Push or pull fan to desired tilt angle. The tilt range is 0°-18°. Tilt position is fixed at 15° and cannot be adjusted.
Unit vibrates excessively	Accumulation of soil on impeller Worn or broken rubber feet Blower impeller has lost balance Blower impeller has been bent Bent motor shaft	FS FS AST AST AST	Clean impeller Replace rubber feet Balance or replace blower wheel Replace blower wheel Replace motor



9 | Spare Parts

Model GX200

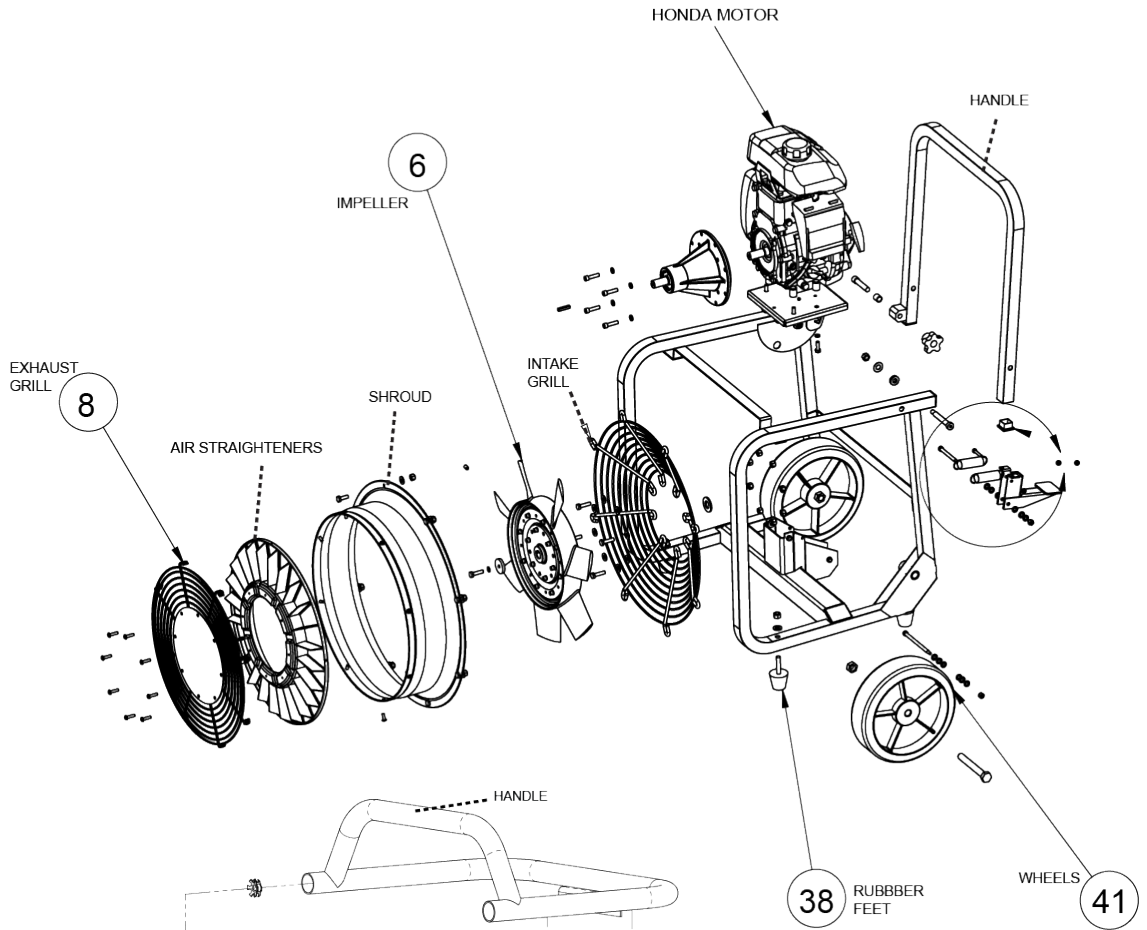

Model GX200L

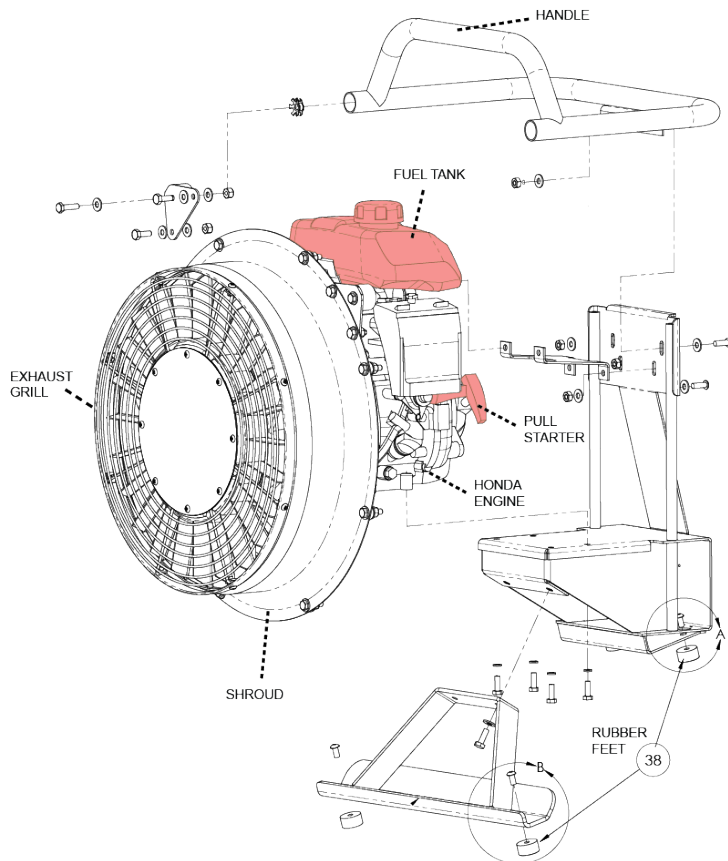



Corresponding Bubble No.	HONDA P/N	Description
-	See Honda Engine Manual	Oil Filter
-	See Honda Engine Manual	Air Filter
-	See Honda Engine Manual	Spark Plug
Corresponding Bubble No.	RAMFAN P/N	Description
6	BL2002	Impeller
8	GG7012	Finger Guard
38	FZ-51368	Rubber Feet
41	GG0315	Wheels – GX200 Only

For additional spare parts, call Euramco Safety +1.619.670.9590 or email theteam@euramcosafety.com or refer to Honda Engine Manual.